

WORKBENCH CASTER

Installation Instructions

4197

Version 2.0

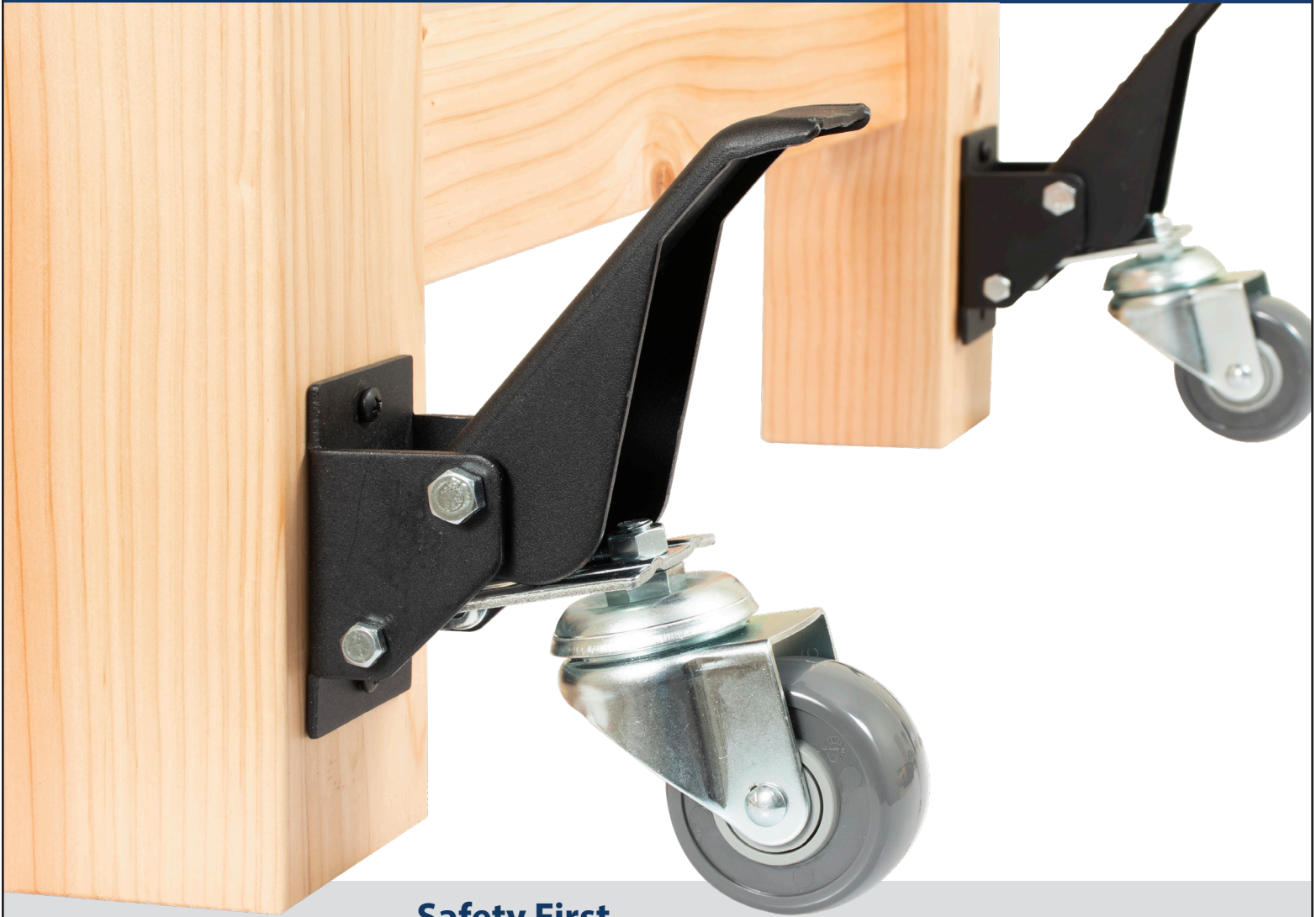

Safety First



Disconnect machine from power source before making any adjustments.



Always wear proper ear protection when working with machinery.



Use caution when handling sharp objects (saw blades, router bits, drill bits and so on). Use protective gloves whenever possible.



Always wear proper eye protection when working with machinery and tools.



Always wear proper respiratory protection when working near airborne dust particles.

Please read and fully understand any and all safety materials that came with your power tools or machinery before operation. Always follow all safety guidelines set in place by the power tool or machine manufacturer.



Prepare your Workbench Leg

Mark and Drill Pilot Holes

1. Measure 2½" from the base of your workbench leg and make a mark on the center of the leg.
2. Place the assembly mount plate onto the leg and align the bottom hole of the plate with the mark.
3. Make sure the plate is straight and mark the top side hole (4-¾" from the base of the leg) on to the leg. Remove the plate.
4. Drill a 5/32" pilot hole at the two marked locations. Only drill into the leg about 1" deep. Do not drill all the way through.

Shop Tip

When drilling your holes, be sure to keep the drill at 90 degrees to the leg.

Mount the Foot Pedal Assembly

Mount with wood screws

1. Place the foot pedal assembly back on to the leg and align the holes on the plate with the drilled holes on the leg.
2. Secure the foot pedal assembly using the supplied wood screws.

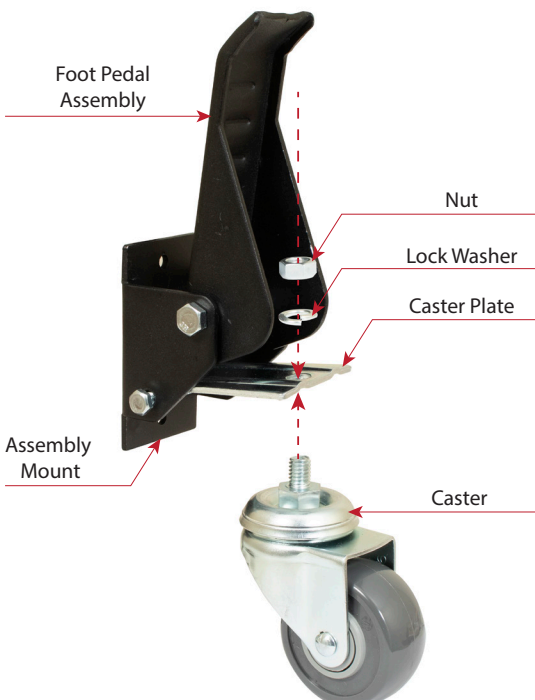
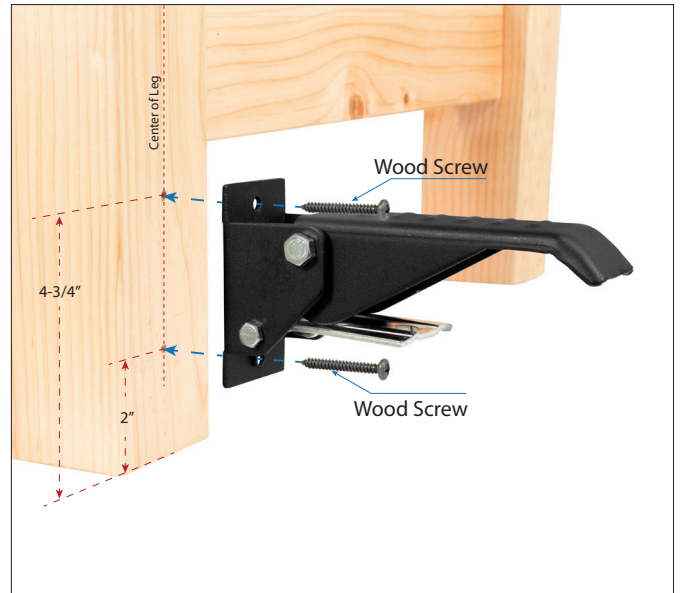

Assemble the Caster

1. Raise the foot pedal to the upward position
2. Insert the caster wheel threaded stud through hole on the caster plate
3. Place the lock washer on to the threaded stud of the caster.
4. Thread the nut on to the threaded stud of the caster
5. Secure the nut tightly with a wrench or ratcheting socket.



Repeat Process for All 4 Legs

Once completed with the first leg, repeat this process for the remaining legs on your workbench.

Your Workbench is Now Mobile!

Now your ready to quickly and easily raise your workbench off the floor and move it as needed.



*Now Available
your choice of quick mount...*

QUICK RELEASE MOUNTING PLATES

Sold Separately

PIN LOCK



SPRING LOCK



Workbench casters aren't just for workbenches...

The workbench casters can be mounted to many different machines, cabinets or tables. Depending on where you mount the casters, you may need to use bolts with nuts instead of wood screws. Nuts and bolts not included.



CAUTION When using your workbench machinery, stands or shop cabinets, make sure the casters are dis-engaged and the machine, stand or cabinet is sitting flat on the floor.



Cut Template on Dotted Lines

